

# LEVELERS

Capacities up to 43,000 lbs.

## APPLICATIONS:

- Business machines, peripherals
- Assembly and manufacturing machinery
- Medical and laboratory equipment
- Any device requiring leveling for uneven floors or work surfaces



### LIGHT DUTY LEVELERS - Series LLD

- Peripherals, test equipment, etc. up to 500 lbs (227 kg) capacity each.
- Bases: Delrin®, non-skid, anti-vibration, steel, stainless to 2" diameter.
- Imperial stem sizes from 8-32 to 1/2" - 13 x 1/2" to 4" long.
- Metric stem sizes available on many models.



### MEDIUM DUTY LEVELERS - Series LMD

- Mainframes, UPS units, etc. up to 2,400 lbs (1,090 kg) capacity each.
- Bases: Delrin®, non-skid, anti-vibration, steel, stainless to 4" diameter.
- Imperial stem sizes from 10-24 to 1"- 8 x 1" to 4 1/4" long.
- Metric stem sizes from M-6 to M-24 x 38.8mm to 88mm long.



### HEAVY DUTY LEVELERS - Series LHD

- Machinery & equipment of all types to 43,000 lbs (19,543 kg) capacity each.
- Bases: Delrin®, non-skid, steel, and stainless to 5" diameter.
- Imperial stem sizes from 3/8" .16 to 1 1/4" - 7 x 6" long.
- Metric stem sizes from M-10 to M-24 x 51mm to 88mm long.



## BASE MATERIALS



NON-SKID (NS)



DELRIN® (D)



STEEL (S)



STAINLESS (SS)



ANTI-VIBRATION - AV (OPTIONAL)

## LEVELER STEMS



IMPERIAL  
THREAD



METRIC THREAD  
(OPTIONAL)



STAINLESS STEEL  
(OPTIONAL)



DELRIN®  
(OPTIONAL)



THREADED  
SOCKET

# LEVELERS

General Purpose Group

- Capacities to 500 lbs.
- Stems from 8-32 to 1/2" diameters. Up to 6" long  
Metric sizes available from M-6 to M-24 x up to 152.4mm long
- All base materials available

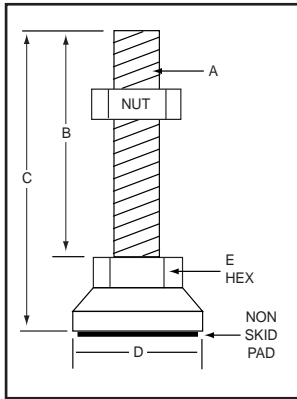

## STYLES ON THIS PAGE

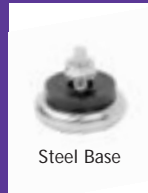

Steel Base

A

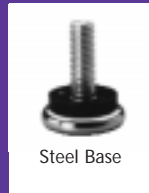

Steel Base

B

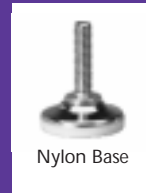

Nylon Base

C

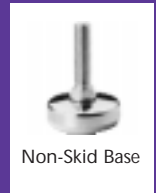

Non-Skid Base

D

STEM SIZE "A"	STEM LENGTH "B"	TOTAL HEIGHT "C"	BASE DIAMETER "D"	HEX YES/ NO "E"	BASE STYLE	MAXIMUM STATIC LOAD (lbs)	PART NUMBER
<b>LIGHT DUTY (SERIES LLD):</b>							
8 - 32	1/2" *	13/16"	1 1/16"	NO	A	75	LLD-S- A-801
1/4 -20	1/2"	31/32"	7/8"	NO	B	100	LLD-S-B-1401
1/4 -20	1"	1 7/16"	7/8"	NO	B	100	LLD-S-B-1402
1/4 -20	1/2"	7/8"	1 1/16"	NO	B	100	LLD-S-B-1403
1/4 -20	1/2"	15/16"	1 1/8"	NO	C	100	LLD-N-C-1404
1/4 -20	1"	1 1/16"	1 1/16"	NO	B	100	LLD-S-B-1406
1/4 -20	1"	1 13/32"	1 1/8"	NO	C	100	LLD-N-C-1407
5/16 -18	1 1/2"	1 3/4"	1 1/2"	NO	C	150	LLD-N-C-502
5/16 -18	1"	1 9/16"	1 3/8"	NO	D	125	LLD-N-D-503
5/16 -18	1 1/2"	2"	1 1/4"	NO	B	125	LLD-S-B-504
5/16 -18	1 1/2"	2 1/8"	1 3/8"	NO	D	150	LLD-NS-D-506
5/16 -18	2"	2 25/32"	1 3/8"	YES	D	150	LLD-N-D-507
3/8 -16	1"	1 5/16"	1 1/4"	NO	B	250	LLD-S-B-301
3/8 -16	1 1/2"	2 9/32"	1 3/8"	NO	D	250	LLD-NS-D-303
3/8 -16	1 1/2"	2 9/32"	1 11/16"	YES	D	350	LLD-N-D-304
3/8 -16	3" **	3 3/4"	1 3/8"	YES	D	250	LLD-NS-D-305
3/8 -16	3 1/2"	4 5/16"	1 11/16"	YES	D	250	LLD-NS-D-306
3/8 -16	3 1/2"	4 5/16"	1 11/16"	YES	D	350	LLD-N-D-307
1/2 -13	2 1/2"	3 3/8"	1 11/16"	YES	D	500	LLD-NS-D-1201
1/2 -13	3" **	3 7/8"	1 11/16"	YES	D	500	LLD-NS-D-1202
1/2 -13	4" **	4 3/4"	1 11/16"	YES	D	500	LLD-NS-D-1203

Note: \* Indicates "Nut Included", \*\* Indicates "Stem Top Slotted for Screwdriver"

# LEVELERS

Professional Group

- Capacities to 43,000 lbs.
- Large load pad
- 15° swivel - hardened ball stud
- Gold chromate zinc finish Standard. Black chromate finish available
- Steel, stainless steel, Delrin® and non-skid bases
- Stud or socket style bases
- Jam nut included
- Specials available
- Metric sizes available

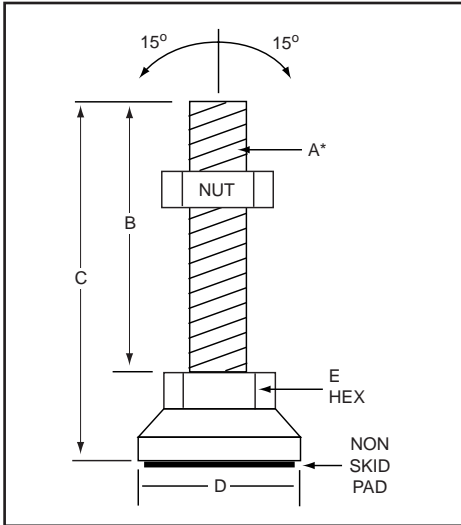

## STYLES ON THIS PAGE



E



F

STUD/ SOCKET SIZE "A"	STUD LENGTH LENGTH "B"	TOTAL HEIGHT "C"	BASE DIAME- TER "D"	MAX. STATIC LOAD (lbs)	STANDARD STUD "E" PART NUMBER	STAINLESS STUD "E" PART NUMBER	STANDARD SOCKET "F" PART NUMBER	STAINLESS SOCKET "F" PART NUMBER
<b>MEDIUM DUTY (SERIES LMD) &amp; HEAVY DUTY (SERIES LHD):</b>								
<b>STEEL BASE:</b>								
10-32	1"	1 17/32"	3/4"	700	LMD-S-E-1001	LMD-SS-E-2001	LMD-S-F-1001	LMD-SS-F-2001
1/4-20	1 1/4"	1 61/64"	1"	1,000	LMD-S-E-1002	LMD-SS-E-2002	LMD-S-F-1002	LMD-SS-F-2002
3/8-16	2"	2 7/8"	1 1/4"	3,750	LHD-S-E-1001	LHD-SS-E-2001	LHD-S-F-1001	LHD-SS-F-2001
1/2-13	2"	3 1/8"	1 7/8"	5,000	LHD-S-E-1002	LHD-SS-E-2002	LHD-S-F-1002	LHD-SS-F-2002
5/8-11	2"	3 1/4"	2 1/2"	6,000	LHD-S-E-1003	LHD-SS-E-2003	LHD-S-F-1003	LHD-SS-F-2003
3/4-10	2"	3 1/2"	3"	7,400	LHD-S-E-1004	LHD-SS-E-2004	LHD-S-F-1004	LHD-SS-F-2004
1-8	4 1/4"	6 1/8"	4"	20,000	LHD-S-E-1005	LHD-SS-E-2005	LHD-S-F-1005	LHD-SS-F-2005
1 1/4-7	6"	8 3/4"	6"	43,000	LHD-S-E-1006	LHD-SS-E-2006	LHD-S-F-1006	LHD-SS-F-2006
<b>NON-SKID BASE:</b>								
10-32	1"	1 21/32"	3/4"	150	LLD-NS-E-1001	LLD-NS-E-2001	LLD-NS-F-1001	LLD-NS-F-2001
1/4-20	1 1/4"	2 5/64"	1"	200	LLD-NS-E-1002	LLD-NS-E-2002	LLD-NS-F-1002	LLD-NS-F-2002
3/8-16	2"	3"	1 1/4"	300	LLD-NS-E-1003	LLD-NS-E-2003	LLD-NS-F-1003	LLD-NS-F-2003
1/2-13	2"	3 1/4"	1 7/8"	700	LMD-NS-E-1001	LMD-NS-E-2001	LMD-NS-F-1001	LMD-NS-F-2001
5/8-11	2"	3 3/8"	2 1/2"	1,200	LMD-NS-E-1002	LMD-NS-E-2002	LMD-NS-F-1002	LMD-NS-F-2002
3/4-10	2"	3 5/8"	3"	1,800	LMD-NS-E-1003	LMD-NS-E-2003	LMD-NS-F-1003	LMD-NS-F-2003
1-8	4 1/4"	6 1/4"	4"	2,000	LMD-NS-E-1004	LMD-NS-E-2004	LMD-NS-F-1004	LMD-NS-F-2004
1 1/4-7	6"	8 7/8"	6"	38,000	LHD-NS-E-1001	LHD-NS-E-2001	LHD-NS-F-1001	LHD-NS-F-2001
<b>DELTRIN® BASE:</b>								
10-32	1"	1 17/32"	3/4"	150	LLD-D-E-1001	LLD-D-E-2001	LLD-D-F-1001	LLD-D-F-2001
1/4-20	1 1/4"	1 61/64"	1"	200	LLD-D-E-1002	LLD-D-E-2002	LLD-D-F-1002	LLD-D-F-2002
3/8-16	2"	2 7/8"	1 1/4"	300	LLD-D-E-1003	LLD-D-E-2003	LLD-D-F-1003	LLD-D-F-2003
1/2-13	2"	3 1/8"	1 7/8"	700	LMD-D-E-1001	LMD-D-E-2001	LMD-D-F-1001	LMD-D-F-2001
5/8-11	2"	3 1/4"	2 1/2"	1,200	LMD-D-E-1002	LMD-D-E-2002	LMD-D-F-1002	LMD-D-F-2002
3/4-10	2"	3 1/2"	3"	1,800	LMD-D-E-1003	LMD-D-E-2003	LMD-D-F-1003	LMD-D-F-2003
1-8	4 1/4"	6 1/8"	4"	2,000	LMD-D-E-1004	LMD-D-E-2004	LMD-D-F-1004	LMD-D-F-2004
1 1/4-7	6"	8 3/4"	6"	3,200	LHD-D-E-1001	LHD-D-E-2001	LHD-D-F-1001	LHD-D-F-2001

\* No stud included with Socket Model "F" Levelers "

# LEVELERS

## Thermoplastic Base Group

- Capacities to 4,500 lbs.
- Reinforced black polyamide (nylon) footplate
- Stud-zinc plated steel standard. Stainless and metric available
- Non-skid, black, NBR rubber pad. 70A shore hardness
- Stainless jam nut included

### STYLES ON THIS PAGE

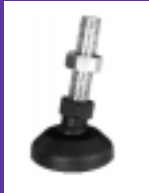

G



H



J



MODEL J WITH HOLES

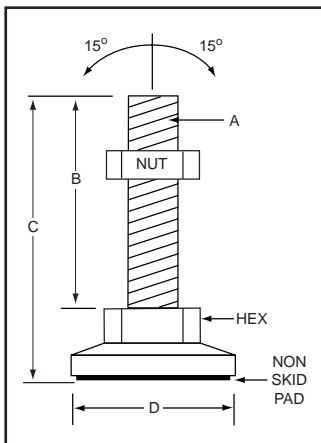

STEM SIZE "A"	STEM LENGTH "B"	TOTAL HEIGHT "C"	BASE DIA. "D"	STYLE & BASE MAT'L	MAX. STATIC LOAD (lbs)	PART NUMBER
5/8"-11	5.91"	7.64"	2.36"	G - Nylon	450	LLD-N-G-3001
5/8"-11	5.91"	7.64"	2.36"	G - Non-Skid	450	LLD-NS-G-3002
5/8"-11	5.91"	7.72"	4.02"	H - Nylon	2250	LMD-N-H-3001
5/8"-11	5.91"	7.72"	4.02"	H - Non-Skid	2250	LMD-NS-H-3002
5/8"-11	5.91"	8.13"	4.33"	J - Nylon	4500	LHD-N-J-3001
5/8"-11	5.91"	8.13"	4.33"	J - Non Skid	4500	LHD-NS-J-3002
3/4"-10	5.91"	7.64"	2.36"	G - Nylon	450	LLD-N-G-4001
3/4"-10	5.91"	7.64"	2.36"	G - Non-Skid	450	LLD-NS-G-4002
3/4"-10	5.91"	7.72"	4.02"	H - Nylon	2250	LMD-N-H-4001
3/4"-10	5.91"	7.72"	4.02"	H - Non-Skid	2250	LMD-NS-H-4002
3/4"-10	5.91"	8.13"	4.33"	J - Nylon	4500	LHD-N-J-4001
3/4"-10	5.91"	8.13"	4.33"	J - Non Skid	4500	LHD-NS-J-4002

\*STYLE "J" MAY BE DRILLED FOR (2) .45 INCH MOUNTING HOLES.



THREAD SIZE	TUBE SIZE O.D. (in)	TUBE WALL THICKNESS (in)	MAX. STATIC LOAD (lbs)	PART NUMBER
<b>ROUND:</b>				
5/8"- 11	1.5"	.065"	1125	RD-100
5/8"-11	2.0"	.065"	1125	RD-200
3/4"-10	2.0"	.065"	1800	RD-300
<b>SQUARE:</b>				
5/8"-11	1.5"	.065"	1125	SQ-100
5/8"-11	2.0"	.065"	1125	SQ-200
3/4"-10	1.5"	.065"	1800	SQ-300
3/4"-10	2.0"	.065"	1800	SQ-400

# LEVELERS

Special Purpose

*Caster-Pro offers levelers for every imaginable device - high tech, medical, industrial, food processing.*



**LOW PROFILE STYLE "K"**

- Capacity 1,500-6,000 lbs
- Steel or stainless
- 3/8" -16 to 3/4" -10 studs up to 6" long
- Steel or vibration dampening bases
- Zinc plated
- 15° swivel



**ANTI-VIBRATION MODEL "L"**

- Capacity 50 to 27,100 lbs
- Steel or stainless
- Imperial or metric
- Stud or socket styles
- 3/8" -16 to 1 1/4" -7 studs up to 6" long.
- Possible to reduce transmitted vibration of most machinery up to 98%



**ANTI-VIBRATION MODEL "M"**

- Machine mounts to 4,140 lbs
- Zinc plated or zinc/safety yellow finish
- M12 - M20 stud
- Vibration element. NBR black, oil resistant rubber. Hardness 80 shore "A"



**STEEL BASE MODEL "N"**

- Capacity to 2,250 lbs
- Steel or stainless
- 3/4" -10, 1 1/8" -7, M-20, M-24 or M-30 studs
- 8° swivel
- With or without mounting holes



**100% DELRIN MODEL "P"**

- All Delrin® stud and base
- Capacity to 300 lbs.
- 3/8"-16 to 5/8"-11 studs up to 2" long

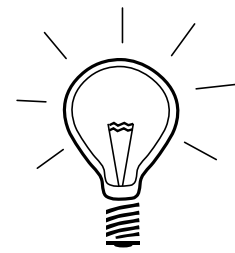

**YOUR CUSTOM LEVELER**

- Custom designed to fit your application
- Any material
- Any finish
- Any size