

SERIES 1 MEDIUM DUTY

Capacities to 600 lbs.

Standard Features

- **Swivel Casters** - Formed legs are continuously welded, top plate is cold forged from $\frac{1}{4}$ " steel and heat treated to relieve stress and add strength

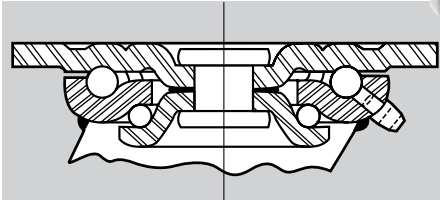

- **Main Load Bearing** - Fully hardened $\frac{5}{16}$ " diameter ball bearings in a hardened raceway provide top performance under maximum rated loads
- **Thrust Bearing** - Large diameter, hardened ball bearings roll freely in a hardened raceway
- **King Pin** - Coined and stress relieved king pin holds raceways precisely in alignment
- **Wheel Bearings** - Roller bearing, or Delrin bearings are available when required
- **Lube Fittings** - Provided for both swivel and wheel bearings when required
- **Finish** - Zinc finish is standard

Standard Top Plate

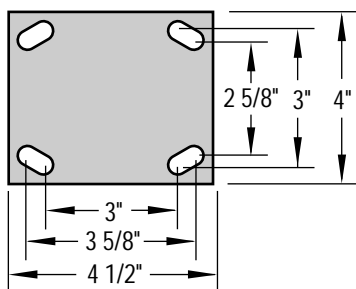

S141R-MR



Optional Features

- **4 Position Swivel Lock** - (Suffix -SL)
- **Delrin Bearing** - (Change R to D)
Example: S141D-PH
- **Wheel Brake, Cam Style** - (Suffix -WB)

Cam Style Brake



APPLICATION:

A good choice where application requires a basic wheel material and capacities of 600 lbs. or less.

The $3 \frac{1}{4}$ " wheel models are particularly well suited for applications where a high capacity is required with an extremely low overall height.



R141R-SS

4 Position Swivel Lock



Wheel Specifications						Caster Specifications						Part Number	
Dia. "A" Inches (mm)	Tread Inches (mm)	Wheel Composition	Ref. to Page	Bearing Type	Axle Dia. Inches (mm)	Load Capacity lbs. (KGS)	Overall Height "B" Inches (mm)	Swivel Radius Inches (mm)	Attach. Bolt Inches (mm)	Approx. Shipping Wt.		Swivel Caster	Rigid Caster
										Swivel lbs. (KGS)	Rigid lbs. (KGS)		
3 1/4 (83)	1 1/2 (38)	Cast Iron	86	Roller	1/2 (13)	600 (270)	4 1/4 (108)	1 3/4 (44)	3/8 (10)	4.5 (2.0)	4.0 (1.8)	S131R-SS	R131R-SS
		Phenolic	82	Roller		600 (270)				3.0 (1.4)	2.5 (1.13)	S131R-PH	R131R-PH
		Mold-on Rubber (Cast Iron Core)	74	Roller		240 (108)				4.5 (2.0)	4.0 (2.8)	S131R-MR	R131R-MR
		Polyurethane (Cast Iron Core)	78	Roller		500 (225)				4.5 (2.0)	4.0 (1.8)	S131R-PI	R131R-PI
4 (102)	1 1/2 (38)	Cast Iron	86	Roller	1/2 (13)	550 (248)	5 5/8 (143)	3 5/8 (92)	3/8 (10)	5.0 (2.3)	4.5 (2.0)	S141R-SS	R141R-SS
		Phenolic	82	Roller		600 (270)				3.5 (1.6)	3.0 (1.4)	S141R-PH	R141R-PH
		Mold-on Rubber	74	Roller		250 (113)				5.0 (2.3)	4.5 (2.0)	S141R-MR	R141R-MR
		Polyurethane (Cast Iron Core)	78	Roller		400 (180)				5.0 (2.3)	4.5 (2.0)	S141R-PI	R141R-PI
		Polyolefin (Blk)	81	Roller		400 (180)				3.5 (1.6)	3.0 (1.4)	S141R-PB	R141R-PB
		Polyolefin (Wt)	81	Delrin		350 (157)				3.5 (1.6)	3.0 (1.4)	S141D-PW	R141D-PW
5 (127)	1 1/2 (38)	Cast Iron	86	Roller	1/2 (13)	600 (270)	6 1/2 (165)	4 1/2 (108)	3/8 (10)	5.5 (2.5)	5.0 (2.3)	S151R-SS	R151R-SS
		Phenolic	82	Roller		600 (270)				4.0 (1.8)	3.5 (1.6)	S151R-PH	R151R-PH
		Mold-on Rubber (Cast Iron Core)	74	Roller		250 (113)				5.5 (2.5)	5.0 (2.3)	S151R-MR	R151R-MR
		Polyurethane (Cast Iron Core)	78	Roller		450 (202)				5.5 (2.5)	5.0 (2.3)	S151R-PI	R151R-PI
		Polyolefin (Blk)	81	Roller		450 (202)				4.0 (1.8)	3.5 (1.6)	S151R-PB	R151R-PB
		Polyolefin (Wt)	81	Delrin		400 (180)				4.0 (1.8)	3.5 (1.6)	S151D-PW	R151D-PW
6 (152)	1 1/2 (38)	Cast Iron	86	Roller	1/2 (13)	600 (270)	7 1/2 (191)	5 (127)	3/8 (10)	6.5 (2.9)	6.0 (2.7)	S161R-SS	R161R-SS
		Phenolic	82	Roller		600 (270)				5.5 (2.5)	5.0 (2.3)	S161R-PH	R161R-PH
		Mold-on Rubber (Cast Iron Core)	74	Roller		300 (135)				6.5 (2.9)	6.0 (2.7)	S161R-MR	R161R-MR
		Polyurethane (Cast Iron Core)	78	Roller		550 (248)				6.5 (2.9)	6.0 (2.7)	S161R-PI	R161R-PI
		Polyolefin (Blk)	81	Roller		450 (202)				5.5 (2.5)	5.0 (2.3)	S161R-PB	R161R-PB
		Polyolefin (Wt)	81	Delrin		400 (180)				5.5 (2.5)	5.0 (2.3)	S161D-PW	R161D-PW

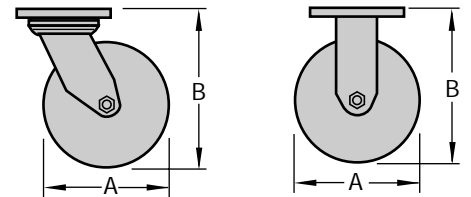

SERIES 1 MEDIUM HEAVY DUTY

Capacities to 1200 lbs.

Standard Features

- **Swivel Casters** - Formed legs are continuously welded, top plate is cold forged from 1/4" steel and heat treated to relieve stress and add strength
- **Main Load Bearing** - Fully hardened 5/16" diameter ball bearings in a hardened raceway provide top performance under maximum rated loads
- **Thrust Bearing** - Large diameter hardened ball bearings roll freely in a hardened raceway

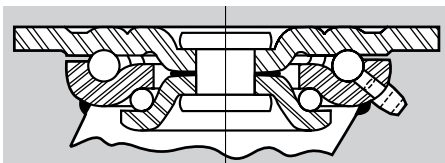

- **King Pin** - 3/4" Coined and stress relieved king pin holds raceways precisely in alignment
- **Wheel Bearings** - Roller bearings are available standard for all wheel sizes
- **Finish** - Corrosion resistant zinc

S182R-SP



- Pre-Notched raceway for field installable Swivel Lock
- **Lube Fittings** - Provided for both swivel and wheel bearings

Optional Features

- **Swivel Bearing Grease Seals** - (Suffix -GS)
- **Delrin Bearing** - (Change R to D)
Example: S162D-PH
- **4 Position Swivel Lock** - (Suffix -SL)
(plunger only part No.1SL-N)
- **Top Locking Wheel Brake** - (Suffix -TLB)
Available on 4", 5", 6" and 8" diameters. See page 104



R162R-PB



- **Wheel Brake** - (Suffix -WB)
 - 4" to 8" Swivel Brake - Tread contact type. Brake shoe grips across and into tread for secure hold: field installable (see price list for brake kit)
 - 3 1/4" Swivel Brake - Cam style. This brake utilizes a larger lever for effective cam action locking of the wheel. This style brake may also be adapted to rigid casters. Not field installable. (See page 104)

Wheel Specifications					Caster Specifications						Part Number		
Dia. "A" Inches (mm)	Tread Inches (mm)	Wheel Composition	Ref. to Page	Bearing Type	Axle Dia. Inches (mm)	Load Capacity lbs. (KGS)	Overall Height "B" Inches (mm)	Swivel Radius Inches (mm)	Attach. Bolt Inches (mm)	Approx. Shipping Wt.		Swivel Caster	Rigid Caster
										Swivel lbs. (KGS)	Rigid lbs. (KGS)		
3 1/4 (82)	2 (50)	Cast Iron	86	Roller	1/2 (13)	700 (315)	4 1/4 (108)	3 3/8 (86)	3/8 (10)	7.4 (3.3)	6.9 (3.2)	S132R-SS	R132R-SS
		Phenolic	82	Roller		700 (315)				5.5 (2.5)	5.0 (2.3)	S132R-PH	R132R-PH
		Mold-on Rubber (Cast Iron Core)	74	Roller		240 (108)				7.4 (3.3)	6.9 (3.2)	S132R-MR	R132R-MR
		Polyurethane (Steel Core)	78	Roller		500 (225)				7.4 (3.3)	6.9 (3.2)	S132R-PI	R132R-PI
4 (102)	2 (50)	Cast Iron	86	Roller	1/2 (13)	800 (360)	5 5/8 (143)	3 3/4 (92)	3/8 (10)	8.5 (3.8)	8.0 (3.6)	S142R-SS	R142R-SS
		Phenolic	82	Roller		800 (360)				6.0 (2.7)	5.5 (2.5)	S142R-PH	R142R-PH
		Mold-on Rubber (Cast Iron Core)	74	Roller		350 (157)				8.5 (3.8)	8.0 (3.6)	S142R-MR	R142R-MR
		Polyurethane (Cast Iron Core)	78	Roller		700 (315)				8.5 (3.8)	8.0 (3.6)	S142R-PI	R142R-PI
		Polyurethane (Alum. Core)	75	Roller		800 (360)				6.5 (2.9)	6.0 (2.7)	S142R-PA	R142R-PA
		Solid Urethane	77	Roller		700 (315)				6.5 (2.9)	6.0 (2.7)	S142R-KT	R142R-KT
		Polyurethane (Polyolefin Core)	80	Roller		700 (315)				6.0 (2.7)	5.5 (2.5)	S142R-PP	R142R-PP
		Polyolefin (Blk)	81	Roller		450 (202)				5.5 (2.5)	5.0 (2.3)	S142R-PB	R142R-PB
	Polyolefin (Wt)	81	Delrin	450 (202)		5.5 (2.5)				5.0 (2.3)	S142D-PW	R142D-PW	
	1 1/2 (38)	Forged Steel	88	Roller		900 (405)				8.5 (3.8)	8.0 (3.6)	S141R-FS	R141R-FS

Wheel Specifications						Caster Specifications						Part Number	
Dia. "A" Inches (mm)	Tread Inches (mm)	Wheel Composition	Ref. to Page	Bearing Type	Axle Dia. Inches (mm)	Load Capacity lbs. (KGS)	Overall Height "B" Inches (mm)	Swivel Radius Inches (mm)	Attach. Bolt Inches (mm)	Approx. Shipping Wt.		Swivel Caster	Rigid Caster
										Swivel lbs. (KGS)	Rigid lbs. (KGS)		
5 (127)	2 (50)	Cast Iron	86	Roller	1/2 (13)	900 (405)	6 1/2 (165)	4 1/4 (108)	3/8 (10)	8.8 (4.0)	8.3 (3.7)	S152R-SS	R152R-SS
		Phenolic	82	Roller		900 (405)				6.5 (3.0)	6.0 (2.7)	S152R-PH	R152R-PH
		Mold-on Rubber (Cast Iron Core)	74	Roller		400 (180)				8.8 (4.0)	8.3 (3.7)	S152R-MR	R152R-MR
		Polyurethane (Cast Iron Core)	78	Roller		900 (405)				8.8 (4.0)	8.3 (3.7)	S152R-PI	R152R-PI
		Polyurethane (Alum. Core)	75	Roller		900 (405)				7.0 (3.2)	6.5 (3.0)	S152R-PA	R152R-PA
		Solid Urethane	77	Roller		900 (405)				7.0 (3.2)	6.5 (3.0)	S152R-KT	R152R-KT
		Polyurethane (Polyolefin Core)	80	Roller		750 (337)				6.5 (3.0)	6.0 (2.7)	S152R-PP	R152R-PP
		Santoprene (Polyolefin Core)	72	Roller		450 (202)				6.5 (3.0)	6.0 (2.7)	S152R-SP	R152R-SP
		Polyolefin (Blk)	81	Roller		650 (292)				6.0 (2.7)	5.5 (2.5)	S152R-PB	R152R-PB
		Polyolefin (Wt)	81	Delrin		600 (270)				6.0 (2.7)	5.5 (2.5)	S152D-PW	R152D-PW
		Forged Steel	88	Roller		1200 (540)				8.8 (4.0)	8.3 (3.7)	S152R-FS	R152R-FS
6 (152)	2 (50)	Cast Iron	86	Roller	1/2 (13)	900 (405)	7 1/4 (184)	5 (127)	3/8 (10)	9.0 (4.1)	8.5 (3.6)	S162R-SS	R162R-SS
		Phenolic	82	Roller		900 (405)				7.0 (3.2)	6.0 (2.7)	S162R-PH	R162R-PH
		Mold-on Rubber (Cast Iron Core)	74	Roller		410 (184)				9.0 (4.1)	8.0 (3.6)	S162R-MR	R162R-MR
		Polyurethane (Cast Iron Core)	78	Roller		900 (405)				9.0 (4.1)	8.0 (3.6)	S162R-PI	R162R-PI
		Polyurethane (Alum. Core)	75	Roller		900 (405)				7.5 (3.4)	6.5 (2.9)	S162R-PA	R162R-PA
		Solid Urethane	77	Roller		900 (405)				7.5 (3.4)	6.5 (2.9)	S162R-KT	R162R-KT
		Polyurethane (Polyolefin Core)	80	Roller		900 (405)				7.0 (3.2)	6.0 (2.7)	S162R-PP	R162R-PP
		Santoprene (Polyolefin Core)	72	Roller		550 (247)				7.0 (3.2)	6.0 (2.7)	S162R-SP	R162R-SP
		Polyolefin (Blk)	81	Roller		700 (315)				6.5 (2.9)	5.5 (2.5)	S162R-PB	R162R-PB
		Polyolefin (Wt)	81	Delrin		650 (292)				6.5 (2.9)	5.5 (2.5)	S162D-PW	R162D-PW
		Forged Steel	88	Roller		1200 (540)				9.3 (4.2)	8.3 (3.7)	S162R-FS	R162R-FS
8 (203)	2 (50)	Cast Iron	86	Roller	1/2 (13)	1050 (473)	9 1/2 (241)	6 1/8 (156)	3/8 (10)	12.0 (5.4)	11.0 (5.0)	S182R-SS	R182R-SS
		Phenolic	82	Roller		900 (405)				8.5 (3.8)	7.5 (3.4)	S182R-PH	R182R-PH
		Mold-on Rubber (Cast Iron Core)	74	Roller		500 (225)				10.5 (4.5)	9.0 (4.1)	S182R-MR	R182R-MR
		Polyurethane (Cast Iron Core)	78	Roller		900 (405)				10.5 (4.7)	9.5 (4.3)	S182R-PI	R182R-PI
		Polyurethane (Alum. Core)	75	Roller		900 (405)				8.0 (3.6)	7.0 (3.2)	S182R-PA	R182R-PA
		Solid Urethane	77	Roller		1000 (450)				8.5 (3.8)	7.5 (3.4)	S182R-KT	R182R-KT
		Polyurethane (Polyolefin Core)	80	Roller		900 (405)				7.5 (3.4)	6.5 (2.9)	S182R-PP	R182R-PP
		Santoprene (Polyolefin Core)	72	Roller		700 (315)				7.5 (3.4)	6.5 (2.9)	S182R-SP	R182R-SP
		Polyolefin (Blk)	81	Roller		800 (360)				6.5 (2.9)	5.5 (2.5)	S182R-PB	R182R-PB
		Polyolefin (Wt)	81	Delrin		700 (315)				6.5 (2.9)	5.5 (2.5)	S182D-PW	R182D-PW

Standard Top Plate #1

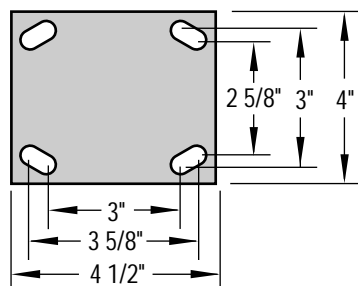

Optional Top Plate #2

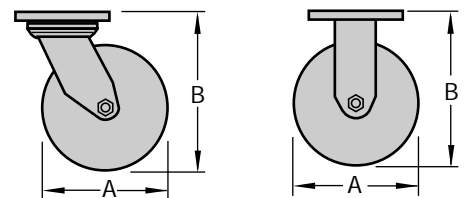
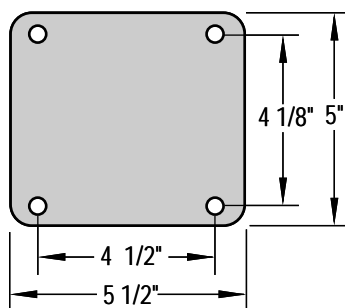

(Change 2nd character in part number)
Example: S262R-PH